

Ultrasonic Transducer Assembled Units

Transducers equip with a 2.5 meters shield cable and covered by a rubber boot with a metal clip for easy installation are very suitable for most of vehicle alarms. RCA, Amp or Molex type connector at the other end of the cable is available upon request.

Specification

Model Number	SQS-04	SQS-05	SQS-06
Transducer used	400ST/R100 or 10P	400ST/R120	400ST/R160 or 16P
Cable length	2.5 meters		
Connector used	RCA/Amp/Molex type or others upon request		

Dimensions

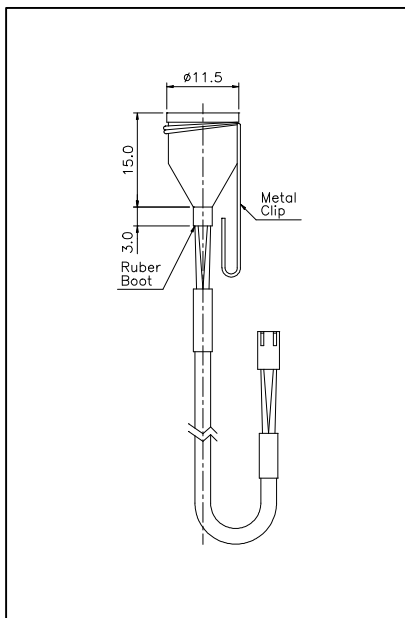

SQS-04

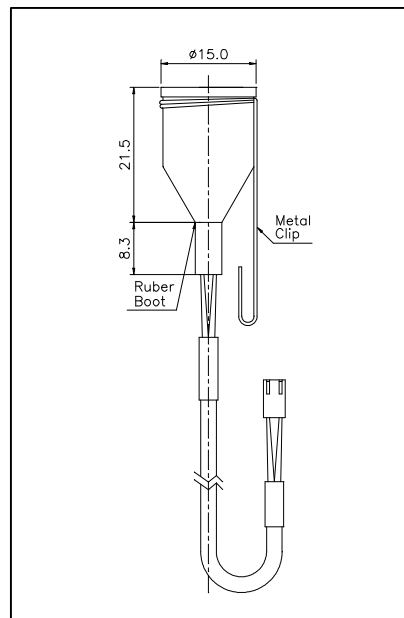

SQS-05

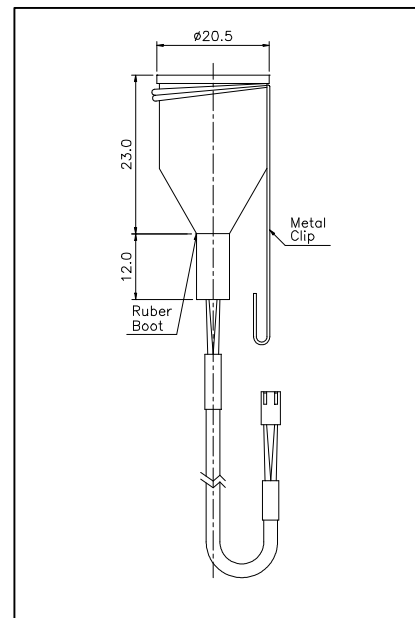

SQS-06

Miniature Tuning Fork Quartz Crystals

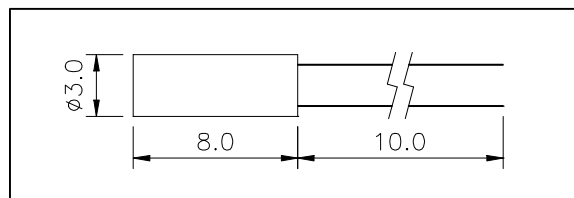
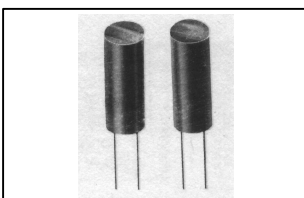

Specification

Model Number	Nominal Frequency Hz	Tolerance at 25°C PPM	Temperature Stability -10°C to +70°C PPM	Load Capacitance pF	Series Resistance Ohm	Shunt Capacitance pF	Drive Level mW
S40000	40,000	± 60	± 45	12.5	35,000	2.3	0.001
S32768	32,768	± 20	± 30	12.5	35,000	2.3	0.001